

PLUG-SOS45XZ

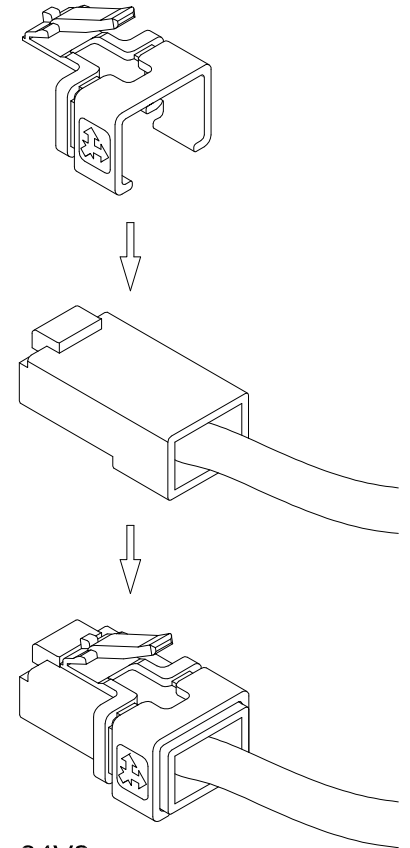
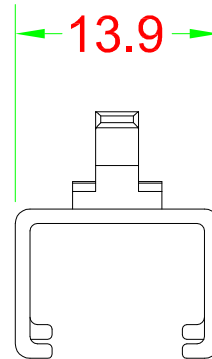
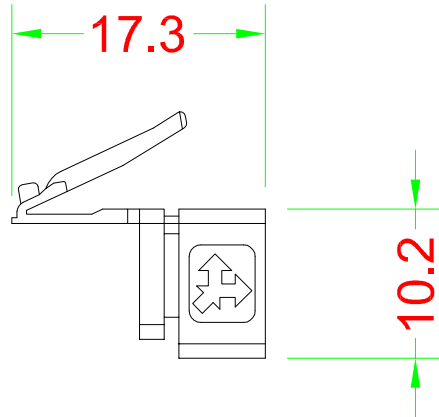
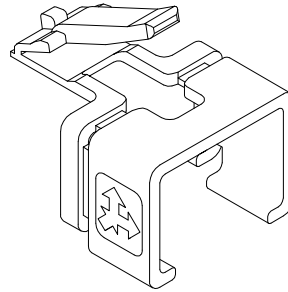
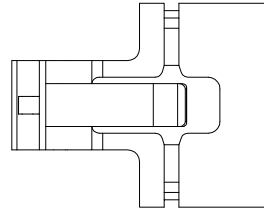

8 colors available : Other colors also available to offer

- | | |
|----------------------|-----------------------|
| 1. Transparent | 5. Transparent green |
| 2. Transparent red | 6. Transparent purple |
| 3. Transparent blue | 7. Transparent yellow |
| 4. Transparent black | 8. Transparent orange |

Package : (Box)

50 pcs



Materials:

Body : Fireproof PC UL-94V2

Insertion Lifetime : Over 1000 Times (min.)

Operation Temperature : -40 °C ~ +70 °C

DRAW NO:		ITEM NO:	NMS-8000K-50
	APPR	CUSTOMER:	
UNIT: m/m	DESIGN	DATE:	
SCALE:	Ref. NO:	TOLERANCE:	X ± 1 · X ± 0.2 · XX ± 0.15



Quest Technology Int'l, Inc.
11200 NW 138th St., Medley, FL 33178
Tel: 305-513-8583 Fax: 305-513-9675
www.QuestTechnologyIntl.com